 **ACQUA Waterfalls by Astral Pool Australia**  
Fully programmable LCD user interface  
**Installation and Operating Instructions**



**Super Bright and Energy Efficient LED Illumination**

AstralPool Australia Pty. Limited. A.B.N. 97 007 284 504

**Melbourne:**

Ph: (03) 8796 8600  
Fax: (03) 8796 8670

**Sydney:**

Ph: (02) 9853 2100  
Fax: (02) 9853 2170

**Brisbane:**

Ph: (07) 3308 5400  
Fax: (07) 3308 5470

**Gold Coast**

Ph: (07) 5552 2600  
Fax: (07) 5552 2670

**Townsville:**

Ph: (07) 4750 3100  
Fax: (07) 4750 3170

**Adelaide:**

Ph: (08) 8152 7600  
Fax: (08) 8152 7670

**Perth:**

Ph: (08) 9350 2600  
Fax: (08) 9350 2670

[www.astralpool.com.au](http://www.astralpool.com.au) email: [service@astralpool.com.au](mailto:service@astralpool.com.au)

Information and specifications subject to change without notice.

**INDEX**

1.0 Introduction.....	3
2.0 Waterfall Installation .....	3
3.0 Grout Guard .....	5
4.0 Rock Trap.....	5
5.0 Pump Selection .....	5
6.0 Mounting the controller .....	6
7.0 Low voltage supply cable colour code.....	6
8.0 Controller and Waterfalls Connection Configuration.....	7
9.0 Acqua Waterfall Controller User Panel .....	8
10.0 Light Engine Replacement – service only .....	12
11.0 Warranty .....	12

<b>1.0 INTRODUCTION</b>
-------------------------

Congratulations on your purchase of a Acqua Waterfall by AstralPool. The Acqua Waterfall incorporates a unique patent pending LED light engine and super-bright RGB LED components. New technology makes our product extremely energy efficient device and suitable for installation in swimming pools, spas and gardens as water feature. The Acqua Waterfall and Controller combination has a with fully programmable user panel to offer: adjustment of the light brightness, speed, the colour selection, making own colour and light fade options. We can offer four different waterfalls length: 600mm, 1200mm, 1800mm and 2400mm. Shown below is the Acqua 1200mm AND Acqua Waterfall Controller..

Correct installation will ensure many years of trouble free use and enjoyment.



Acqua Controller

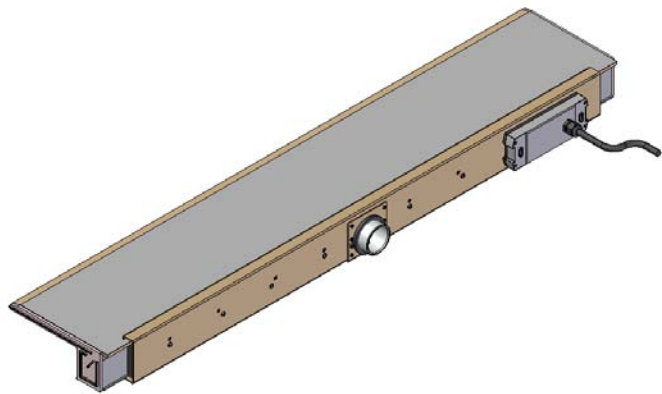

Acqua Waterfall

### Input Power Rating

230–240 VAC – 0.9 Amps.

**NOTE: Handle with care.**

**The Acqua Waterfall in-built electronics and PVC frame are not designed to take heavy shock, hammering or weight and if they are not handled properly can be damaged or it may affect performance.**

**Note:**

The appliance is not intended for use by young children or infirm person without supervision. Please ensure that young children are supervised to ensure that they do not play with the appliance.

## 2.0 WATERFALL INSTALLATION

Qualified person in accordance with AS/NZ 3000:2000 standards must install the Lighting system.

A dedicated plumbing line is recommended for all waterfalls. It is recommended that 50mm PVC pipe be used for all installations and **must be used** where the required flow rate exceeds 200 ltr/min or the total pipe length exceeds 20 metres. The waterfall must be installed before the deck and coping is layed. Acqua waterfalls have **20m** of cable attached.

**NOTE: If the Waterfall is not level when installed the water flow will be un-even! Ensure that the Grout Guard is in place at all times during Installation.**

1. Glue the Rock Trap as close as possible to the inlet so that it will extend beyond the mounting surface. Refer to Fig 1. on Pg 2.
2. It is recommended that 50mm pipe is used for all installations using a coupling to connect the Rock Trap
3. Make a notch, cutout or penetration in the mounting wall face 20mm longer than the length of the waterfall.
4. When installing waterfalls in a sprayed concrete or brick walls, do not tie the waterfall to the Reinforcing Steel or spray in the concrete as they can distort and cause internal damage due to excessive stressing and movement however; provide a penetration using polystyrene or wood, allowing for connection of the pipe work at rear. The Waterfall can then be installed at a later date once the wall has set.

**WATERFALLS ARE NOT DESIGNED TO TAKE HEAVY WEIGHTS AND IF THEY ARE NOT SUPPORTED PROPERLY CAN SERIOUSLY AFFECT THE OVERALL PERFORMANCE.**

5. Knock out the penetration and place the waterfall in the notch, cutout or penetration made on the mounting surface leaving a 10mm gap at each end.

**NOTE: Extended lip models must be sufficiently supported.**

6. Level the waterfall, using packers where necessary.
7. Ensure the waterfalls lip edge will be flush with the finished wall surface.
8. Fill in the area below and in the back with mortar.
9. To ensure the waterfall stays in a level position while the mortar is setting place a piece of wood over the waterfall. Then use bricks or heavy objects placed on top of the wood to allow even weight distribution.
10. Once the mortar is set remove the wood and heavy objects to complete the installation.

**NOTE: Acqua Waterfall cannot have the lip cut.**

**NOTE: Ensure the waterfall has enough clearance at rear for future maintenance, inspection or service.**

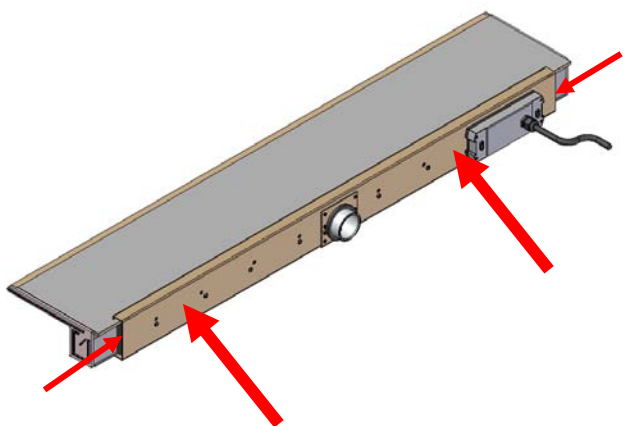

Access to Acqua Waterfall LED Assembly

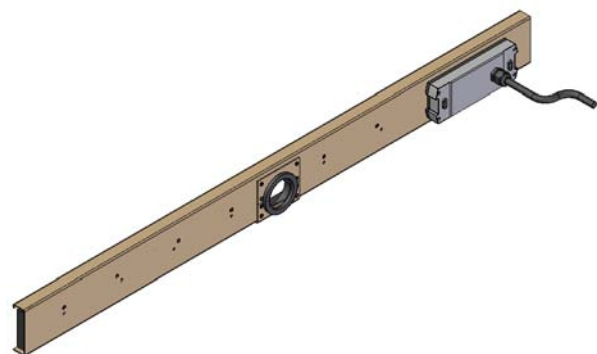

Acqua LED Assembly

### 3.0 GROUT GUARD

The Grout guard is to protect the waterfalls outlet from dirt, dust, mortar and debris while it is been installed.

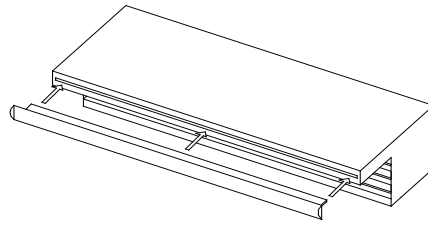

Grout Guard - Remove after Installation

### 4.0 ROCK TRAP

The rock trap filter supplied is to prevent dirt and debris from entering the waterfall. Below is a diagram showing where it should be mounted. For best results mount the rock trap as close to the inlet of the waterfall as possible. The rock trap should always be installed pointing downward.

Fig1.

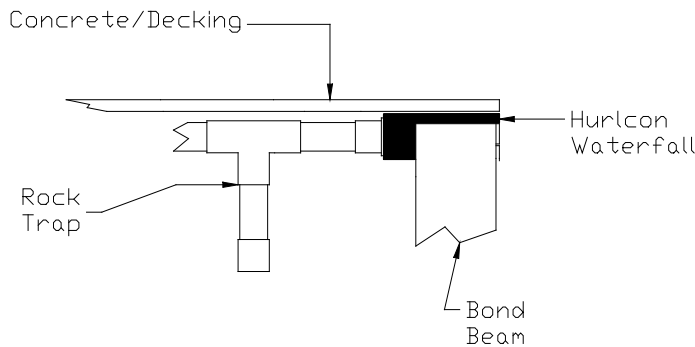

### 5.0 PUMP SELECTION.

Below is a guide as to the pump size required to operate your waterfall efficiently and effectively.

#### PUMP SIZE (Approximate) for WATERFALLS

Cascade Waterfall Length	Required Water Flow - ltr/min/m	Typical Pump Size – Hp	Hurlcon Pump (at 8m Head)
600mm	100	0.50	E 140
1200mm	200	0.75	ECO 230 / CTX 280
1800mm	300	1.50	ECO 230 / CTX 360
2400mm	400	2.00	CTX 400

### Flow Control

A **two-way valve must be installed** on the outlet of the waterfall pump in an accessible area to control the amount of water that exits the waterfall. It will also reduce the risk of damage on start up. Have the valve half open on start up and reduce or increase depending on the desired waterfall effect you wish to achieve.

Waterfalls naturally become narrower as they fall. Below is a recommended guide for the height your waterfall should be installed above the water surface.

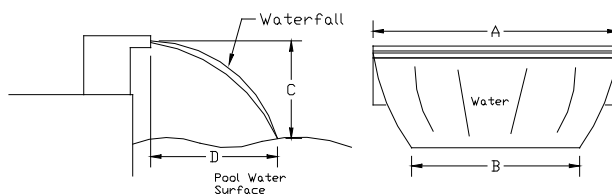

A – Waterfall Length	B – Waterfall Width at Pool Surface at Recommended ltr/min/m	C – Recommended Waterfall Height	D – Water Distance at Recommended ltr/min/m
600mm	500mm	600mm	300mm
1200mm	1100mm	900mm	300mm
1800mm	1700mm	900mm	300mm
2400mm	2300mm	900mm	300mm

## 6.0 MOUNTING THE CONTROLLER

Choose a location that is preferably out of direct sunlight, near the waterfall system and a flat, secure wall or post. The controller should be located 1 metre above ground level to prevent rain splash back or sprinkler system damage to the underside of the controller.

- a) Mount the wall bracket using the screws provided on a secure wall.
- b) Hang Controller on wall bracket and plug power supply lead into 3-pin outlet.
- c) Remove draw for easy access to connection points.
- d) Plug the Waterfall power supply cable into underside of Controller.
- e) Ensure removable draw is replaced on Controller to protect from water ingress.

## 7.0 LOW VOLTAGE SUPPLY CABLE – Waterfall to Controller Connection

**NOTE:** If the power / supply cord is damaged, it must be replaced by the manufacturer or its service agent or a similarly qualified person in order to avoid a hazard.

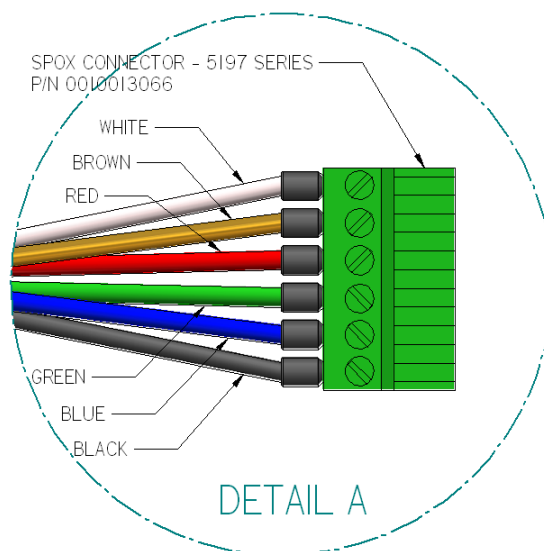

## 8.0 CONTROLLER & WATERFALLS CONNECTION CONFIGURATION

**ACQUA Controller** - One Module with two Channels

**ACQUA2 Controller** - Two Modules (each module has two Channels in total 4 Channels)

**NOTE:** To each Channel can be connected 1200mm long waterfall only. Connecting longer waterfalls may overheat controller's power board.

Example:

Use one Module to connect:

- 2 x 1200mm long waterfalls
- 1 x 1800mm long waterfall
- 1 x 2400mm long waterfall

That means, if we planning to connect 1800mm or 2400mm long waterfall to ACQUA Controller, one cable will be connected to Channel 1 Power and another cable will be connected to Channel 2.

Eg:

### ACQUA Controller – One Module with two Channels

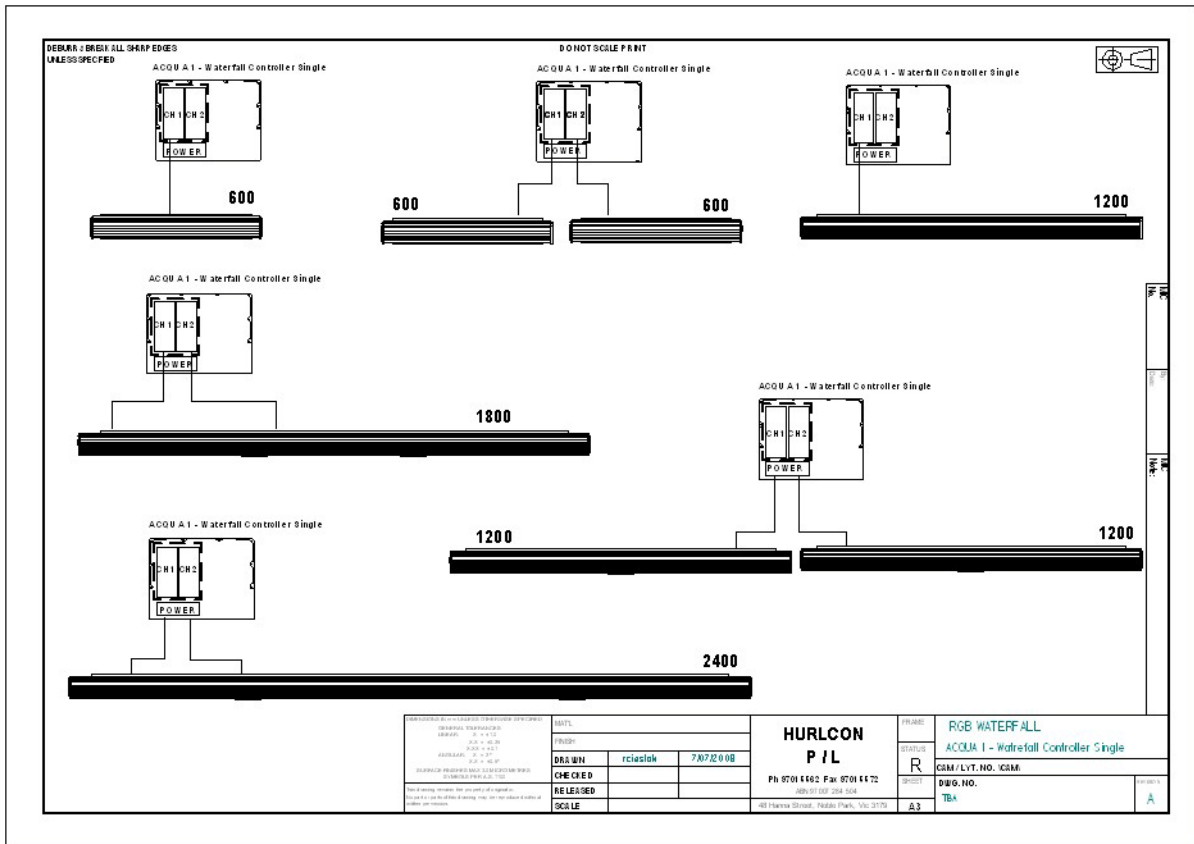

# ACQUA2 Controller – Two Modules with four Channels

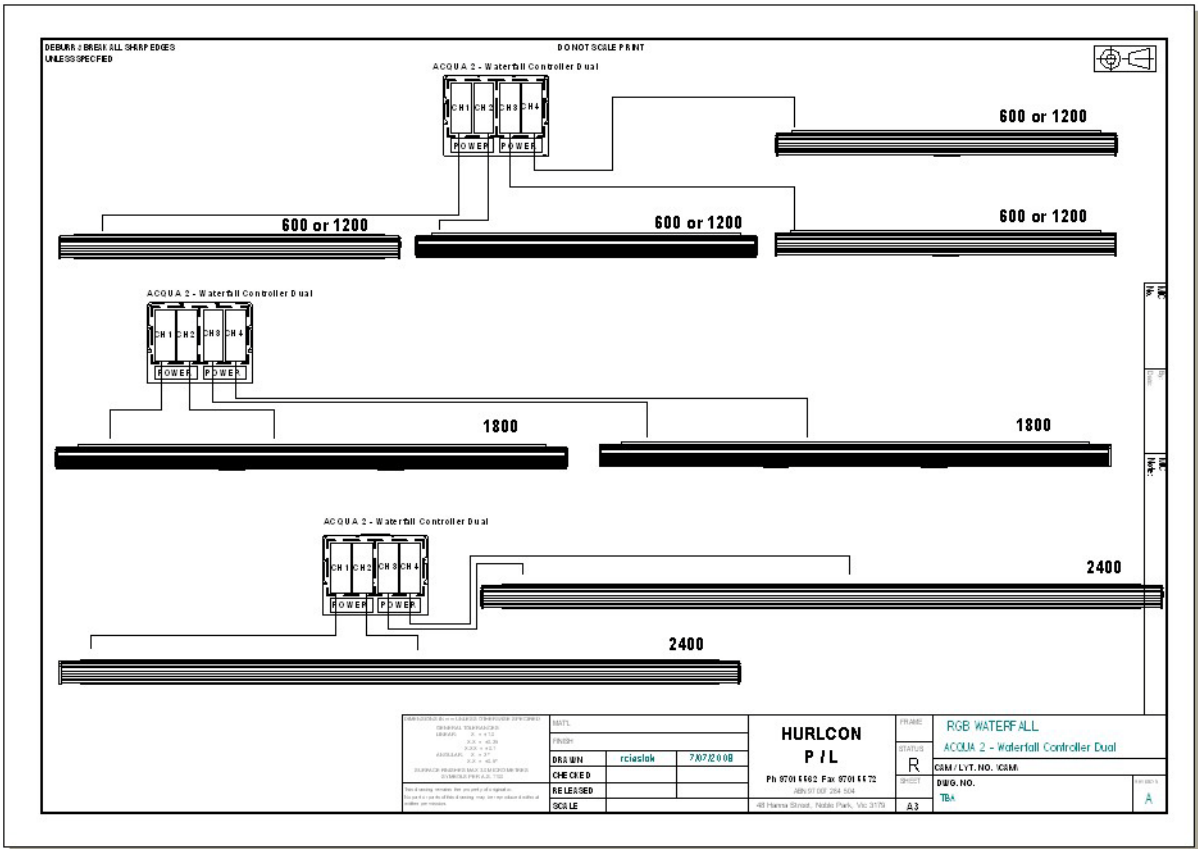

## 9.0 RGB WATERFALL CONTROLLER – User Panel

The Controller operation can be divided into following functions:

- 1) Colours selection – selected colours can be switched ON or OFF permanently
- 2) Tuning the colours – each colour can be tuned up to discretion of the user (it is like adding extra pigment to the paint to make it more greener)
- 3) Mode selection:
  - a) Disco – selected colours (pt.1) will appear in close loop
  - b) Fade – light regression
  - c) Smooth – surf through selected colours at a same time maintain level of brightness (rainbow effect).
  - d) Fade and Smooth time Set Up – Hold time and Change time Set Up
  - e) Make you own extra two colours (User 1, 2) regardless of the factory set up.
- 4) Installer Set Up
  - a) Discover modules – communication check between User Panel and number of installed Power Boards
  - b) Assign modules to zones
  - c) Assign name to zones
  - d) G4 system (if installed)



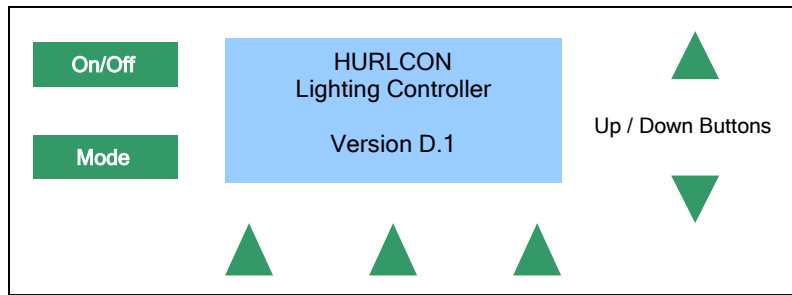

## General Operation

1. Plug into single phase 240V, 3-pin power point
2. Press **On/Off** if required to obtain ON status as depicted. The User Panel remember last status of the On/Off switch. If the user Panel was left ON and mains OFF, the next time User Panel will come to ON by its memory.

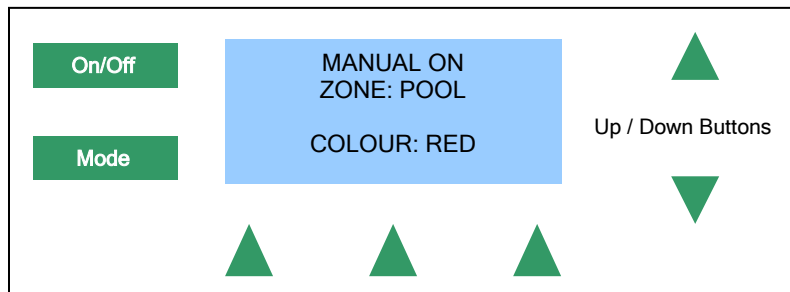

3. Press **MAINT** and press 3 x No until you reach Installer Set Up screen

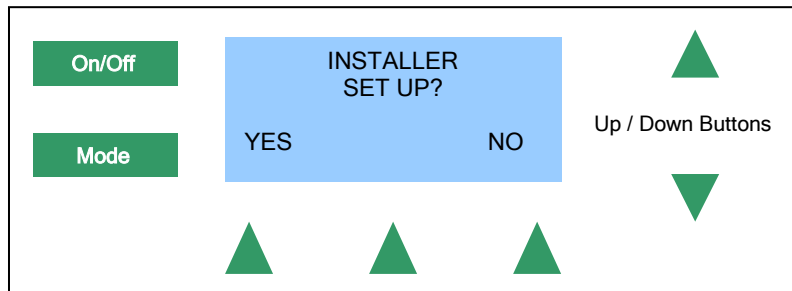

4. Press **YES**
5. The screen will question "DISCOVER MODULES?"
6. Press **YES**, and see screen as below

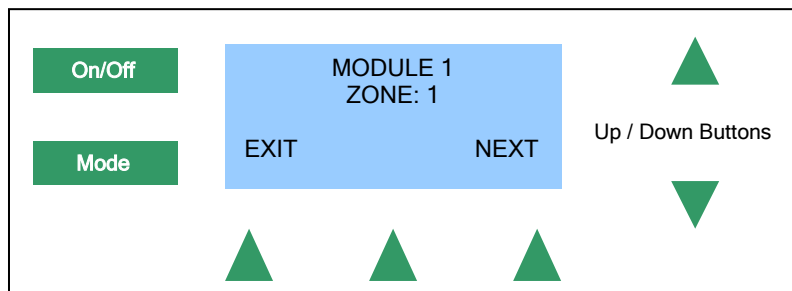

7. Press **Up/Down** and assign Zone to Module 1. There is four ZONES and fifth NONE.
8. Press **NEXT** if you have more than one module. Otherwise screen will display:  
MODULE 2 NOT FOUND.
9. Press **EXIT**

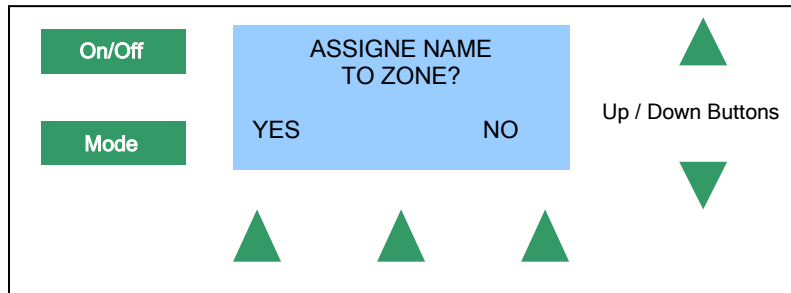

10. Press **YES**

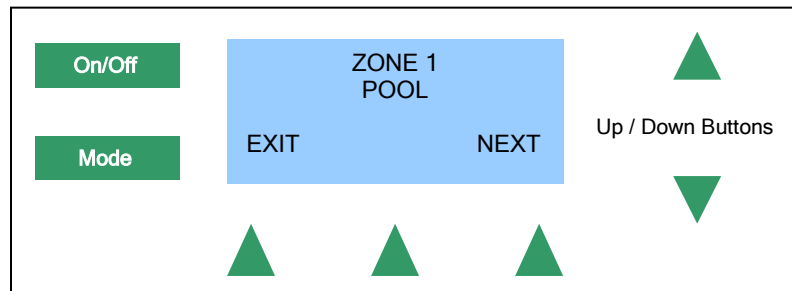

11. Keep pressing Up/Down until you select proper name. The names are: Pool, Spa, Pool&Spa, Waterfall 1,2,3
12. Press **EXIT**
13. Select G4 console if is installed. If is not installed, select Not Installed.
14. Press **ACCEPT**
15. Then back to main screen.

To select colour / Disco / Fade mode start with screen as below:

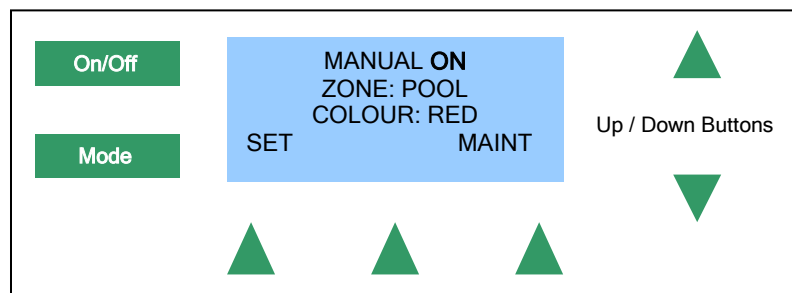

1. Press **SET**

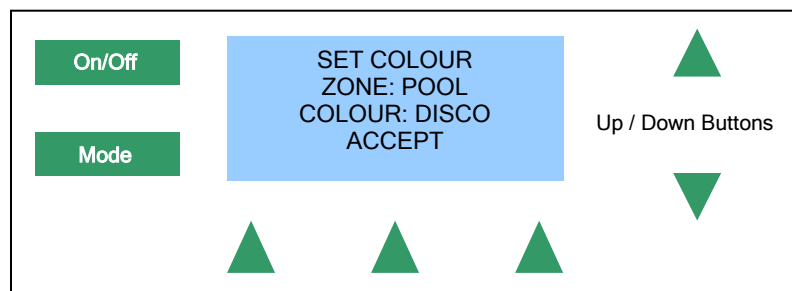

- Keep pressing Up/Down until choose desired function or colour.

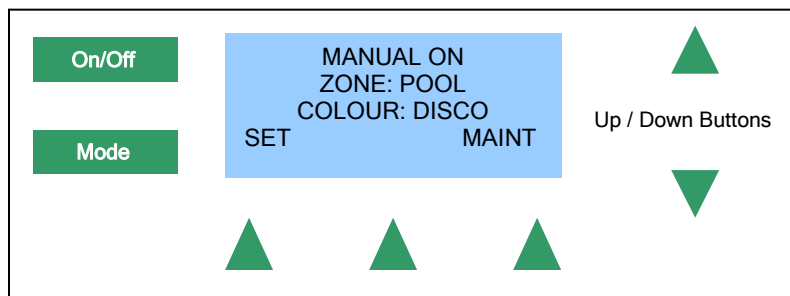

### Colours tuning

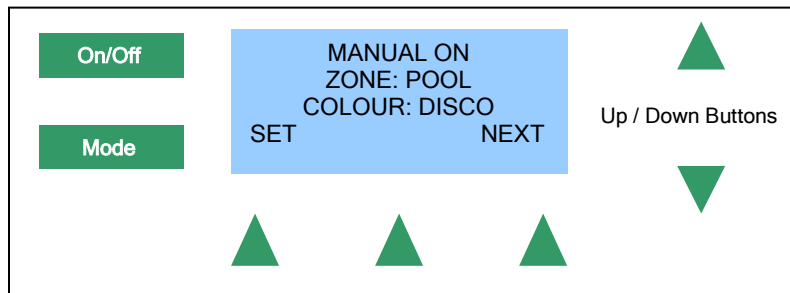

- Press **MAINT**
- Press 2 x **NO** to skip two screens
- This will bring screen: “TUNE COLOURS?”
- Press **YES**
- Select colour for tuning
- Press **YES**
- Screen will ask: “LOAD DEFAULT?”
- If you like factory colour set up, then press **YES**. If you like your own colour makeup, select **NO**.
- If your answer is **NO**, keep pressing Up/Down to adjust strength of the colour in scale from 1 to 100.
- Then press **NEXT** to select next colour for tuning and so on.

### Fade and Smooth Hold and Change time set up

- Press **MAINT** button

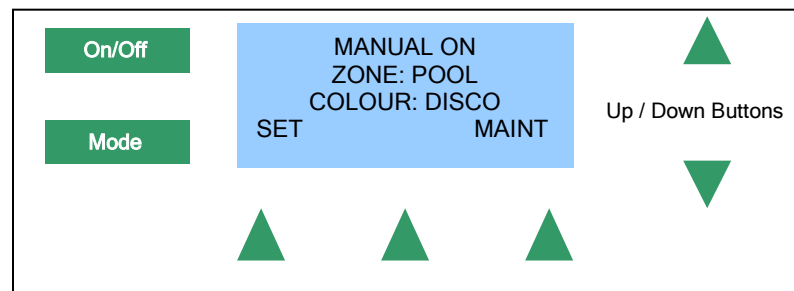

- Press once **NO** to get to screen: **SET FADE AND SMOOTH TIME?**
- Press **YES**
- Press **Up/Down** button to select **HOLD TIME** (15 secs, 1min, 5 min)

5. Press **ACCEPT**
6. This will bring “FADE AND SMOOTH CHANGE TIME?”
7. Press **Up/Down** to select between 10, 20, 60 secs
8. Press **ACCEPT**

<b>10.0 LED REPLACEMENT</b> (Information only for Serviceman)
---

To replace the light engine perform the following steps:

- a) Before you decide to replace light engine, please disconnect low voltage cable from existing installation and re-connect to any spare LED stripe available in your toolbox. Run scan test through the colours to ensure the low voltage cable and controller work normally. If not proceed as below.
- b) Remove cable cover (use PH#1 screwdriver) and disconnect low voltage cable from the light engine socket.
- c) Remove gently the water inlet circular foam seal and push slightly forward. If damaged, remove completely.
- d) Undo four screws (use PH#1 screwdriver) and remove bottom bracket from under the water inlet. The bracket is sealed with silicone and may refuse to go easy. Do not remove top bracket.
- e) Undo M4 screws (use PH#2 screwdriver) which holding the light engine to waterfalls PVC frame.
- f) Pull carefully back aluminum rail just to disengage the rail from the waterfall frame.
- g) Remove light engine and replace with new one. Before installation perform light TEST.
- h) Lubricate with small amount of “Hydroslipe” or similar Top and Bottom foam seals of the new light engine. The lubricant will make easier to install new seals on the waterfalls frame.
- i) Insert Rail, then bottom bracket and tight up four screws. Make silicone gasket under the bracket.
- j) Push on rail of the light engine so it seat on the waterfall frame.
- k) Insert M4 screws holding light engine to waterfall frame. Do not over-tight just one screw. Tight up all screws sequentially one at a time, keep tightening all screws in small increments until all screws seats tight enough.
- l) Insert end foam new seals. Use new seals.
- m) Push back water inlet seal. If you decide to use new seal, the seal is a circle and needs to be cut in one place to embrace the water inlet with already installed pipe.
- n) Connect low voltage supply cable to socket.
- o) Re-install plastic cover box.
- p) Perform final check deploying all possible modes / set up the microcontroller can deliver.

## Warranty

Your Acqua Waterfall and Controller is covered by a limited 12 month warranty (plus 30 days to allow for installation) against defects in materials and workmanship. The PowerPack is covered by a 12 month warranty against defects in materials and assembly. Proof of purchase date must be provided if requested.

In field labour warranty is applicable in capital city metropolitan areas or within a 20km radius of an authorised AstralPool service agent. Warranty claims outside of these areas may attract a travelling expense charge.

There are no user serviceable parts. Always turn off and disconnect power supply when removing Light. No representations may be made on AstralPool's behalf by any person unless permission, in writing is obtained from AstralPool.

## Limitations

All warranties only apply if the equipment is installed and operated in complete compliance with the installation and operating instructions.

Specific limitations and exclusions include but are not limited to, water ingress into Power Pack or light assembly, damage caused through excessively rough handling, incorrect termination, connection or alteration to the light cable, and operation of light out of water.

AstralPool assumes no liability for consequential damages of any kind. Should you request a warranty service call and the problem is diagnosed as non-warrantable, you will be charged for a diagnostic service plus any parts and labour required to repair the light. No person is authorised to make any representations on behalf of AstralPool.

---

AstralPool Australia Pty. Limited. A.B.N. 97 007 284 504

<b>Melbourne:</b>	<b>Sydney:</b>	<b>Brisbane:</b>	<b>Gold Coast</b>	<b>Townsville:</b>	<b>Adelaide:</b>	<b>Perth:</b>
Ph: (03) 8796 8600	Ph: (02) 9853 2100	Ph: (07) 3308 5400	Ph: (07) 5552 2600	Ph: (07) 4750 3100	Ph: (08) 8152 7600	Ph: (08) 9350 2600
Fax: (03) 8796 8670	Fax: (02) 9853 2170	Fax: (07) 3308 5470	Fax: (07) 5552 2670	Fax: (07) 4750 3170	Fax: (08) 8152 7670	Fax: (08) 9350 2670

[www.astralpool.com.au](http://www.astralpool.com.au) email: [service@astralpool.com.au](mailto:service@astralpool.com.au)

Information and specifications subject to change without notice.