

**ASTRAL**POOL 

# Jetstream Robotic Pool Cleaner

## INSTALLATION AND OPERATING INSTRUCTIONS



Melbourne: 03 8796 8600  
Sydney: 02 9853 2100  
Brisbane: 07 3308 5400

Gold Coast: 07 5552 2600  
Townsville: 07 4750 3100  
Adelaide: 08 8152 7600

Perth: 08 9350 2600  
sales@astralpool.com.au  
www.astralpool.com.au

A division of

**FLUIDRA**  

## GENERAL

Congratulations on the purchase of your AstralPool Jetstream robotic pool cleaner. The Jetstream pool cleaner uses a powerful jet drive propulsion system to clean your pool. Before you use your cleaner for the first time, please take a few minutes to read carefully these operating and installation instructions.

### Note:

The appliance is not intended for use by young children or infirm person without supervision. Please ensure that young children are supervised to ensure that they do not play with the appliance.

If the supply cord is damaged, it must be replaced by the manufacturer or its service agent or a similarly qualified person in order to avoid a hazard.

**WARNING: DO NOT SWIM WHILE THE CLEANER IS IN USE WITHIN THE SWIMMING POOL**

## CLEANER COMPONENTS

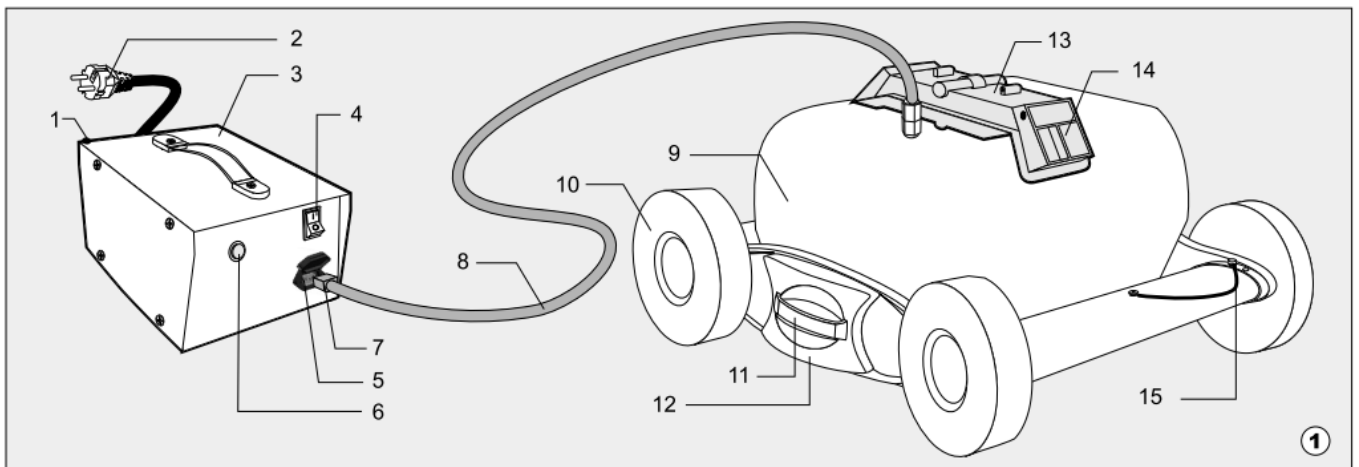

- |                             |                       |
|-----------------------------|-----------------------|
| 1. fuse                     | 9. body               |
| 2. transformer cable plug   | 10. wheel             |
| 3. transformer 230 V ~ 50Hz | 11. handle            |
| 4. power switch ON/OFF      | 12. side plate        |
| 5. socket                   | 13. jet valve housing |
| 6. Selection switch         | 14. jet outlet        |
| 7. floating cable plug      | 15. lock pin          |
| 8. floating cable           |                       |

## OPERATING INSTRUCTIONS - CLEANER

Your new Jetstream robotic pool cleaner contains;

- a) Robotic pool cleaner & floating cable
- b) Power supply unit (transformer)

Please read all sections of this manual prior to operation of your pool cleaner.

1. Place the power supply (transformer) a minimum of 3.5 meters from the edge of the pool. (see Fig 2.)

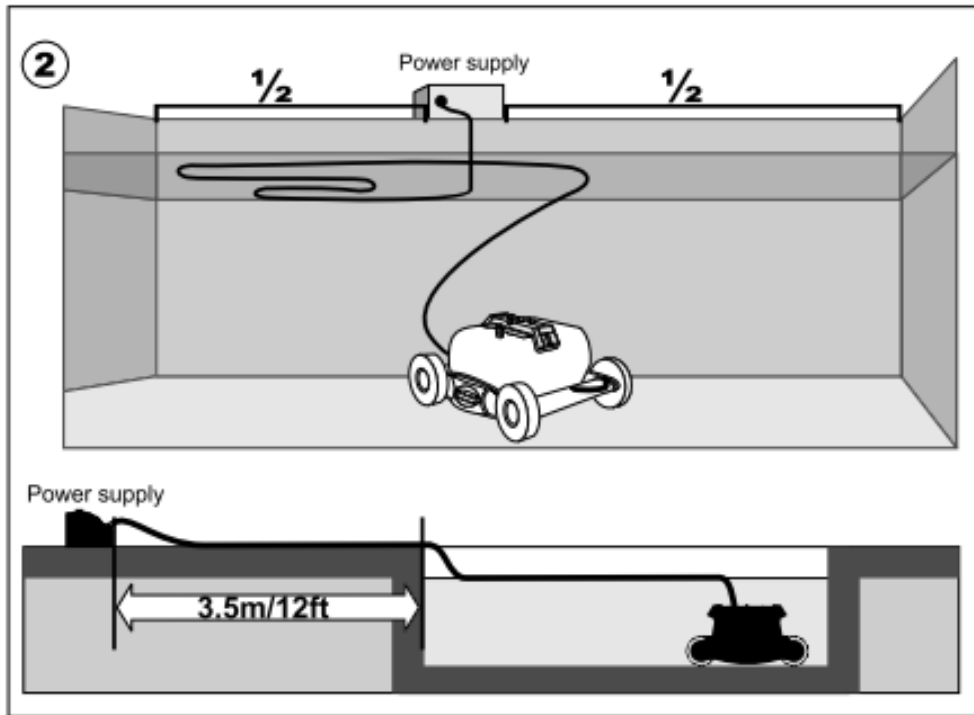

2. Uncoil sufficient cable for the cleaner to reach the furthest point within the pool (see Fig. 3) It is important that you do not put the entire cable into the pool unless required. Excess cable within the pool may lead to tangling and/or twisting of the cable.

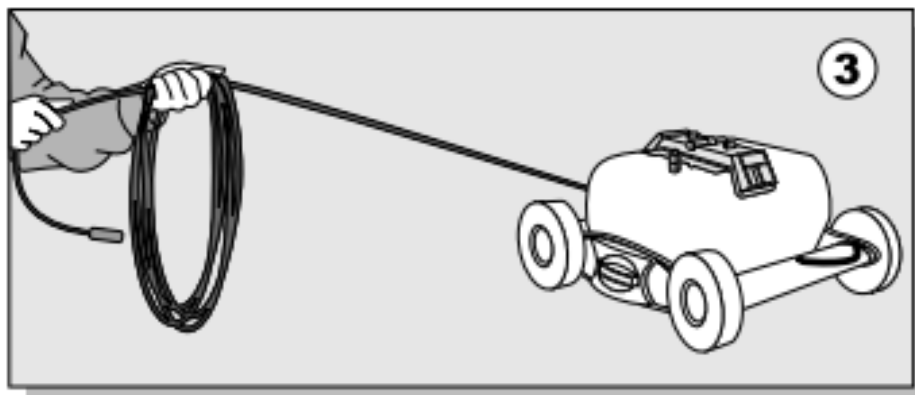

3. Ensure the power supply switch is in the OFF position (see Fig. 4) and plug the cable from the robot cleaner into the power supply (see Fig. 5)

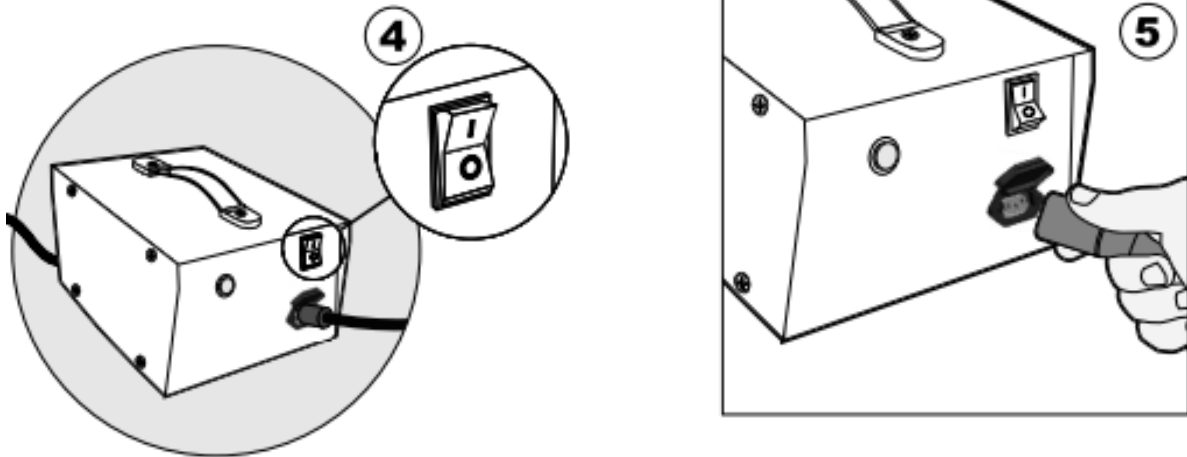

4. Place the cleaner into the water. Turn unit side to side whilst in the water to allow air to escape from the body and then let the cleaner sink to the bottom of the pool (see Fig. 6) Spread the floating cable over the surface of the pool as evenly as possible making sure to avoid kinks or tangles. Reminder: do not add any more cable than required to reach the far corner of the swimming pool.

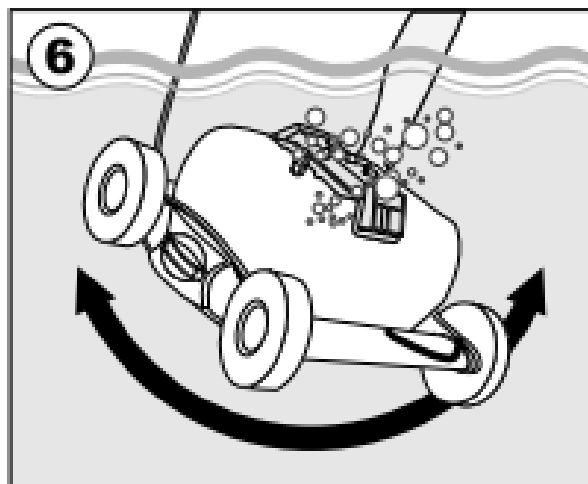

5. Connect the power supply to a grounded power outlet and turn on.

Important: When storing the cleaner, ensure it is located in an area well protected and in a temperature range of 10 to 40 degrees Celsius. Failure to comply may result in loss of warranty.

**CAUTION:** Do not switch the pool cleaner ON if not fully immersed within the swimming pool. Operating the cleaner out of water will cause severe damage immediately and will result in loss of warranty. Allow the cleaner to remain in the pool for 15 – 20 minutes after the completion of a cleaning cycle to allow the motors to cool adequately. Do not leave the cleaner in the pool all the time. Always remember to turn the power supply OFF and unplug from the power outlet prior to removing the cleaner from the water.

## OPERATING INSTRUCTIONS – POWER SUPPLY

1. Insert the plug of the floating cable (1) into the power supply socket (2)
2. The cleaner has 2 cleaning modes;
  - a. Small Pool Mode
  - b. Large Pool Mode

These cleaning programs will adjust the cleaning patters according to your pool side. Select the cleaning programs by using the toggle switch (4) located on the power supply as follows;

- i. For Small Pools – set switch to “O” (5) (Recommended for pools smaller than 25 square metres)
  - ii. For Larger Pools – set switch to “I” (6) (Recommended for pools larger than 25 square metres)
3. Turn the main power switch (3) to ON. The cleaner will now start working. The power supply will shut off automatically when the cleaning cycle has finished. The cleaning cycles are
    - a. 2 hours for Small Pools
    - b. 3 hours for Large Pools
  4. To restart a cleaning cycle, turn power supply OFF, wait 30 seconds and turn ON again.

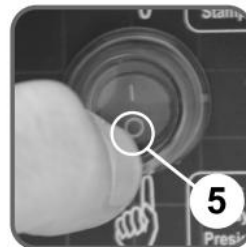
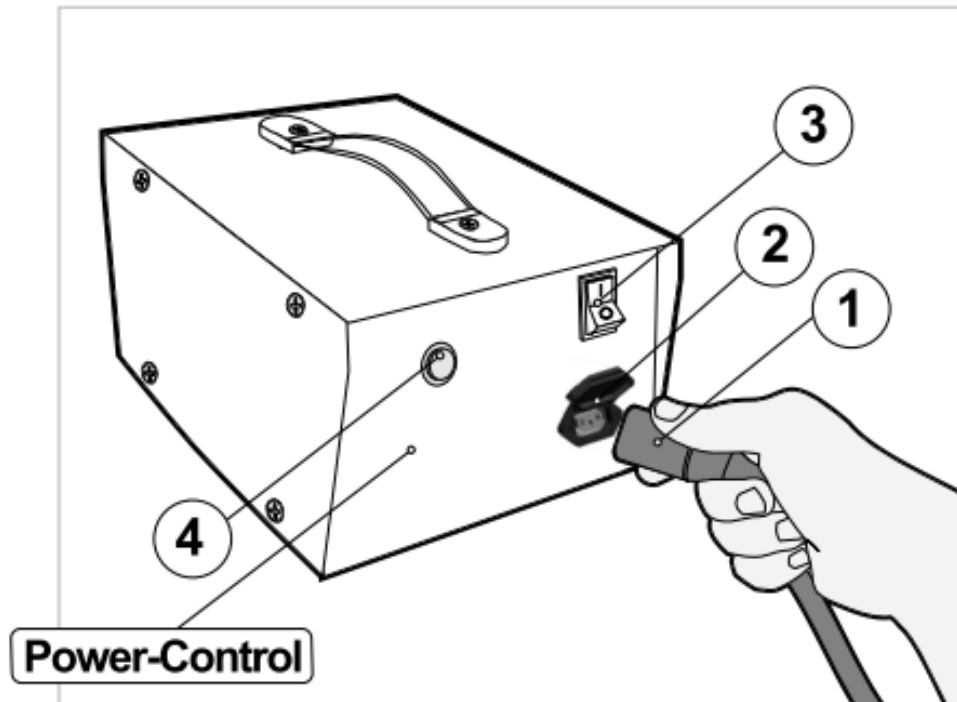

**CAUTION:** TO REDUCE THE RISK OF ELECTRICAL SHOCK, DO NOT REMOVE SCREWS. NO USER SERVICEABLE PARTS INSIDE. REFER SERVICING TO QUALIFIED SERVICE PERSONAL.



Input Rating: 230 V ~ 50Hz. / 230 W / 1.25A.  
Output Rating: stepped down to 36V ~ 50Hz. @ 6A.  
Fuse Rating: 1.25A, 250V SLOW BLOW.

## CLEANING CYCLE

The cleaning cycle of your Jetstream robotic pool cleaner is 2 or 3 hours depending on selection. After the period has finished, the cleaner will automatically switch off through the integrated timer inside the unit. In some cases the pool will be clean after less than 2 hours and at other times the pool will not be clean after a fully completed cycle. The size and shape of the pool and the amount of debris present will determine the total amount of cleaning time required.

When the cleaner slows down and constantly reverses directions before reaching the end sides of the pool, it is sending a signal that it is time to clean or change the filter bag.

## FILTER BAG MAINTENANCE

### CLEAN THE FILTER BAG AFTER EACH CLEANING CYCLE

1. Unplug the power supply (Please keep the plug away from contact with the water)
2. If the unit is in the pool, gently pull the cleaner towards you using the cable until the handle is within reach. Use the side handle (not the cable) or the wheel tube (Fig. 9) to pull the cleaner out of the pool after allowing most of the water to drain from the unit.
3. Lay the cleaner on its back on a smooth surface (in order to prevent scratches on the machine body), unlock and remove the bottom lid assembly. (Fig 10, 11, 12, 13)

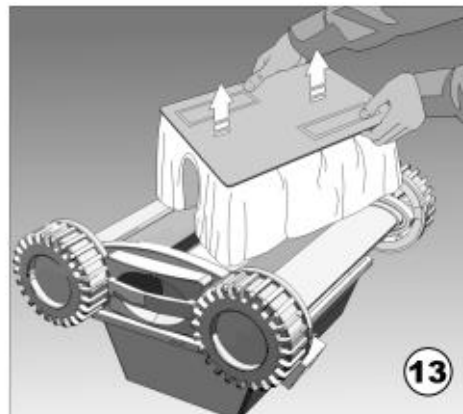
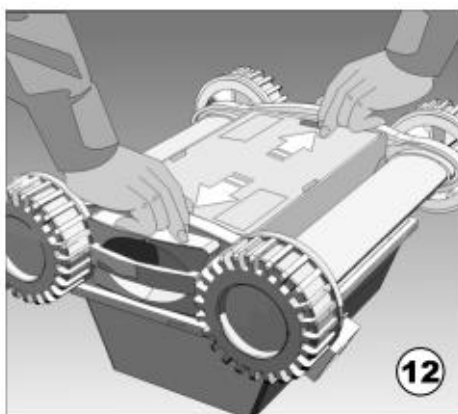
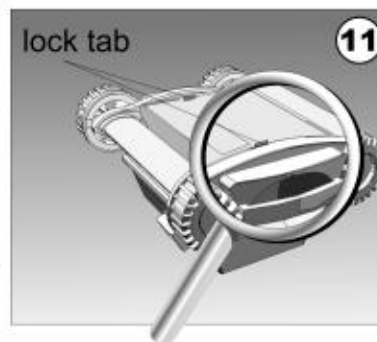
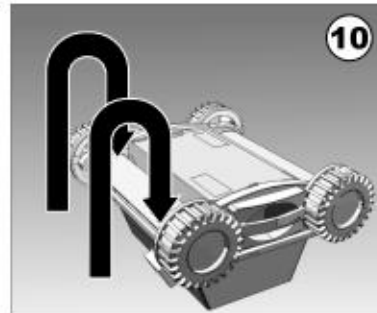
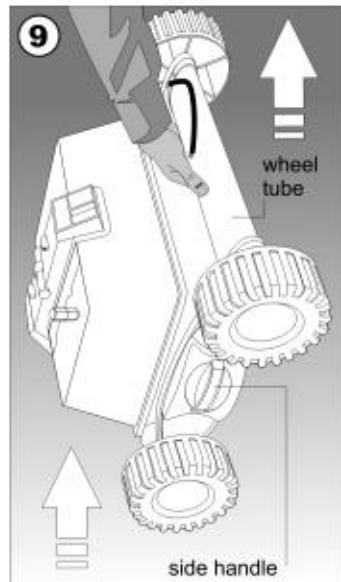

4. Remove the filter bag from the support bars (Fig 14), turn inside out and wash off all the dirt with a garden hose or in a sink. Squeeze the bag gently until the rinse water is clear. If necessary, machine wash the bag using only cold water with NO DETERGENT!
5. Re-install the bag on the support bars with the label in the centre of one of the long sides of the bottom lid (Fig 15)

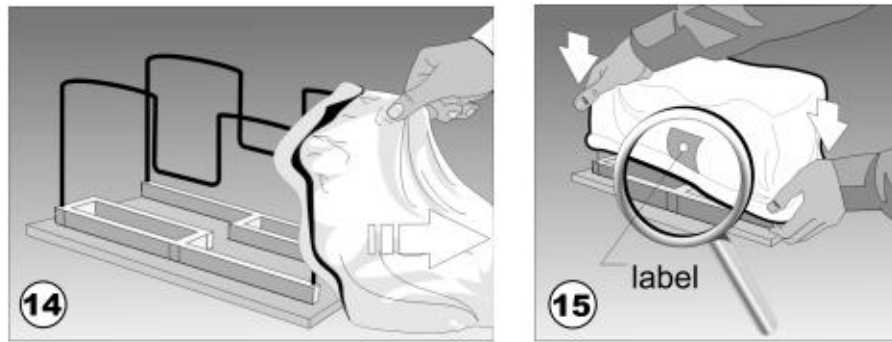

6. Re-install the bottom lid assembly in the body. Push down on it until the lock tabs will snap into place properly.

## SETTING THE CLEANING PATTERN

Your Jetstream robotic pool cleaner uses a systematic cleaning pattern that allows the cleaner to go back and forth in overlapping patterns. The cleaner may be used to clean a variety of different size pools. Before its first use, you must set the cleaner up for your pool. To adjust the cleaner you will use the axle locking pin (Fig 17) permanently attached to the unit with a lanyard.

For most pools ranging from 24m to 27m in length, the cleaner has to be set to look like the picture in Fig 16 with the lock pin installed in the rear position. The cleaner will clean the pool in a consistent pattern. To increase the turning radius, the lock pin can be moved into the forward position (Fig 18).

After your cleaner completes its cycle, remove the cleaner from the pool and transfer the lock pin to the opposite side of the axle. By doing this, the next time your cleaner is put into the pool it will work in the opposite pattern to ensure the best coverage of the pool floor.

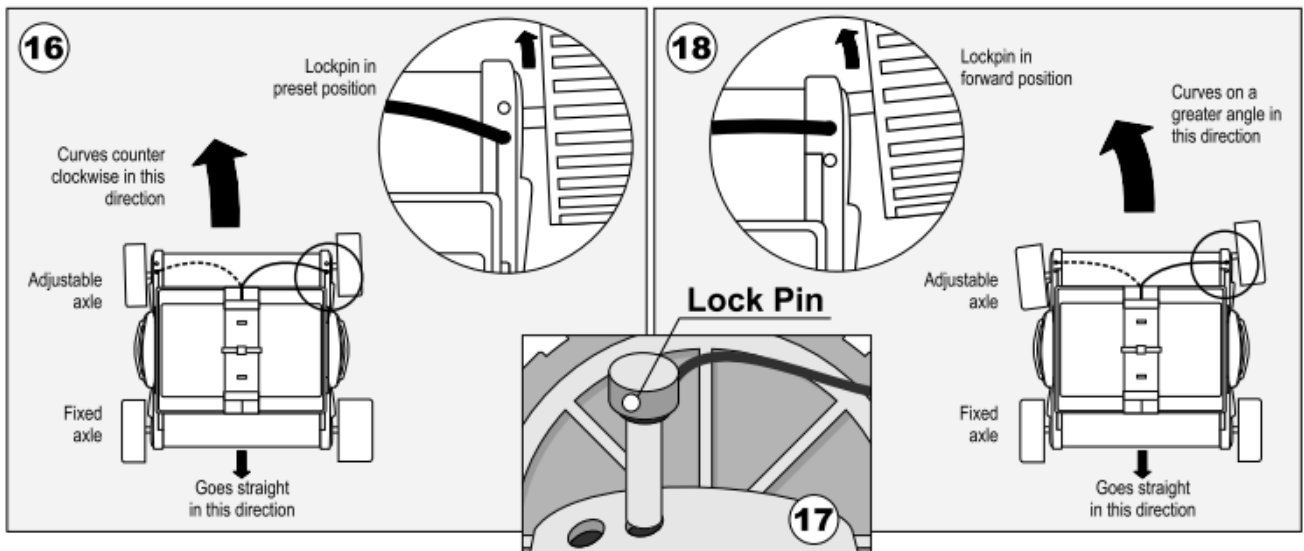

## TROUBLE SHOOTING

---

### A. Unit does not reverse directions

- a) Take garden hose and spray water into the valve housing at each opening. The high water pressure should free the jet valve system of any debris.

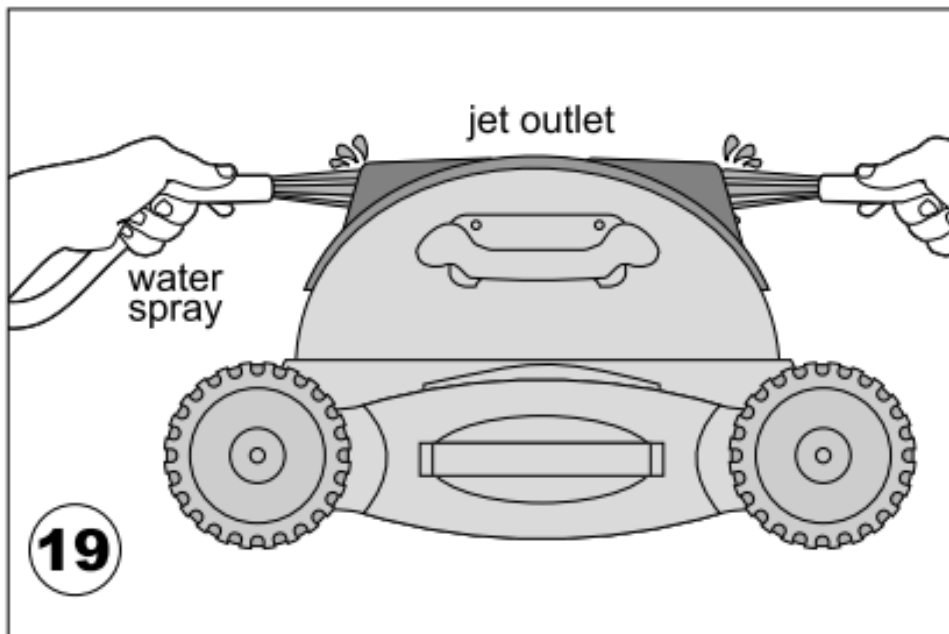

### B. Does not pump water

- a) Check to see if the power socket has power
- b) Check to see if the cable is connected to the power supply.
- c) Check the fuse in the power supply, if required replace it.
- d) Check the cable for signs of damage

### C. Does not vacuum well or at all

- a) Check to see if the filter bag is clean
- b) Check to see if the intake valve flaps on the bottom of the cleaner are free to allow entry of water and debris.

### D. Does not cover the entire pool

- a) Check to see if the wheel movement is free of obstructions like hair or accumulated debris.
- b) Check to see if the filter bag is clean.
- c) Adjust operation cycle so the cleaner reaches the other side of the pool.

## WARRANTY

---



AstralPool Australia Pty Ltd (ABN 97 007 284 504) ("AstralPool") provides the following warranty in relation to its range of Robotic Pool cleaners ("Product").

*Our goods come with guarantees that cannot be excluded under the Australian Consumer Law. You are entitled to a replacement or refund for a major failure and for compensation for any other reasonably foreseeable loss or damage. You are also entitled to have the goods repaired or replaced if the goods fail to be of acceptable quality and the failure does not amount to a major failure.*

The benefits of this warranty are in addition to any rights and remedies imposed by Australian State and Federal legislation that cannot be excluded. Nothing in this warranty is to be interpreted as excluding, restricting or modifying any State or Federal legislation applicable to the supply of goods and services which cannot be excluded, restricted or modified.

## WARRANTY

AstralPool warrants that, subject to the exclusions and limitations below, the Product will be free from defects in materials and workmanship during the warranty period. The warranty periods are set out below and commence 30 days after the date of purchase (to allow for installation). The warranty period may vary for different parts of the Product.

Product	Warranty Period
Jetstream	2 years (Domestic use only, return to factory for service)

If a defect appears in the Product before the end of the warranty period and AstralPool finds the Product to be defective in materials or workmanship, AstralPool will, in its sole discretion, either:

- (a) Replace or repair the Product or the defective part of the Product free of charge; or
- (b) Cause the Product or the defective part of the Product to be replaced or repaired by an Authorised AstralPool Service Agent free of charge.

AstralPool reserves the right to replace defective parts of the Product with parts and components of similar quality, grade and composition where an identical part or component is not available.

Goods presented for repair may be replaced by refurbished goods of the same type rather than being repaired. Refurbished parts may be used to repair the goods.

## WARRANTY CLAIMS

1. If a fault covered by warranty occurs, the customer must first contact AstralPool at the contact address listed below, or an Authorised AstralPool Service Agent.
2. Any warranty claim must be accompanied by:
  - (a) Proof of purchase;
  - (b) Full details of the alleged defect; and
  - (c) Appropriate documentation (such as historical and maintenance records).
3. The customer must make the Product available to AstralPool or its Authorised AstralPool Service Agent for inspection and testing. AstralPool or its Authorised AstralPool Service Agent will attend the premises where the Product is installed for inspection and testing. If the Product is installed:
  - (a) Outside a capital city metropolitan area; and
  - (B) is not within a 20 km radius of an Authorised AstralPool Service Agent;then the customer may have to pay a travel fee.
4. If such inspection and testing finds no defect in the Product, the customer must pay AstralPool's usual costs of service work and testing. If such inspection and testing finds a defect that is not covered by this warranty, the customer must pay AstralPool's usual costs of service work plus any parts and labour required to repair the Product, unless recoverable from AstralPool on the failure of any statutory guarantee under the ACL.

## Exclusions

The warranty will not apply where:

- (a) The customer is in breach of the Terms and Conditions of Sale;
- (b) The Product was used for a purpose other than one it was intended for;
- (c) The Product was repaired, modified or altered by any person other than AstralPool;
- (d) The Product has not been installed, maintained and/or operated in complete compliance with the installation and operating instructions and any instructions by AstralPool;
- (e) The Product has been subject to accident, negligence, alteration, abuse or misuse.

The warranty does not extend to:

- a) normal wear and tear;
- b) weather and other environmental conditions including but not limited to storm, flood, and/or heat wave damage; or
- c) Service and maintenance items.

Examples of exclusions include but are not limited to:

- wear and tear on wheels and filter bags/cartridges
- jamming of impeller with debris

### **Commercial Installations**

On commercial installations, such as health clubs, motels/hotels and hydrotherapy facilities, the warranty is limited to parts and in field labour (within capital city metropolitan areas or 20 km radius of Authorised AstralPool Service Agents) for a period of 12 months from the date of purchase plus 30 days to allow for installation unless otherwise specified.

### **LIMITATIONS**

AstralPool makes no express warranties or representations other than set out in this warranty.

The repair or replacement of the Product or part of the Product is the absolute limit of AstralPool's liability under this express warranty.



ASTRALPOOL Pty. Limited. A.B.N. 97 007 284 504  
www.astralpool.com.au email: service@astralpool.com.au  
Information and specifications subject to change without notice.

<b>Victoria:</b>	<b>New South Wales:</b>	<b>Queensland:</b>	<b>South Australia:</b>	<b>Western Australia:</b>	<b>Gold Coast:</b>	<b>Townsville:</b>
Ph: (03) 8796 8600	Ph: (02) 9853 2100	Ph: (07) 3308 5400	Ph: (08) 8152 7600	Ph: (08) 9350 2600	Ph: (07) 5552 2600	Ph: (07) 4750 3100
Fax: (03) 8796 8670	Fax: (02) 98532170	Fax: (07) 3308 5470	Fax: (08) 81527670	Fax: (08) 9350 2670	Fax: (07) 5552 2670	Fax: (07) 4750 3170